

### Gozinta Force Transducer

#### FEATURES

- Simple press fit mounting
- Stainless steel construction
- Hermetically sealed
- Corrosion resistant
- Low temperature sensitivity
- Field installable into existing structures
- Measures tension, compression, shear, bending, torsion
- Full double bridge configuration
- Single capacity for all applications



#### DESCRIPTION

An innovative approach to sensor design combined with proven strain gage technology has resulted in a small, accurate stainless steel sensor with wide-ranging application possibilities. The Gozinta® overcomes a number of current sensor problems and limitations such as installation ease, size, load limit, location and operating temperature conditions. In addition, the Gozinta has unchallenged application versatility and a wide range of machines, devices or structures can use Gozinta sensors as a cost-effective, accurate solution to sensing needs.

The Gozinta sensor is mounted into the machine or structure and the sensor's output can be calibrated to meet the system needs.

As a result, the maximum load of the system is determined by the structure, rather than by the sensor. Sensitivity to thermal effects is minimal due to the Gozinta's unique patented design.

The Gozinta is configured with a full bridge circuit for low non-linearity, hysteresis and non-repeatability. A certain degree of care should be taken when positioning or locating the sensor in a structure. In addition, the number of sensors used in a structure, the amount of strain an individual Gozinta senses, and the material of the structure will affect the overall accuracy. Installation is optimized through the use of specific installation tools, supported by extensive application notes.

#### APPLICATIONS

- Agricultural equipment
- Rolling mill sensing
- Stamping press control
- Lift trucks
- Machine tool wear sensing
- Intrusion alarms
- Structural load measuring
- Moment sensing
- Tank weighing systems
- In-rail weighing systems

#### OUTLINE DIMENSIONS in mm (inches)

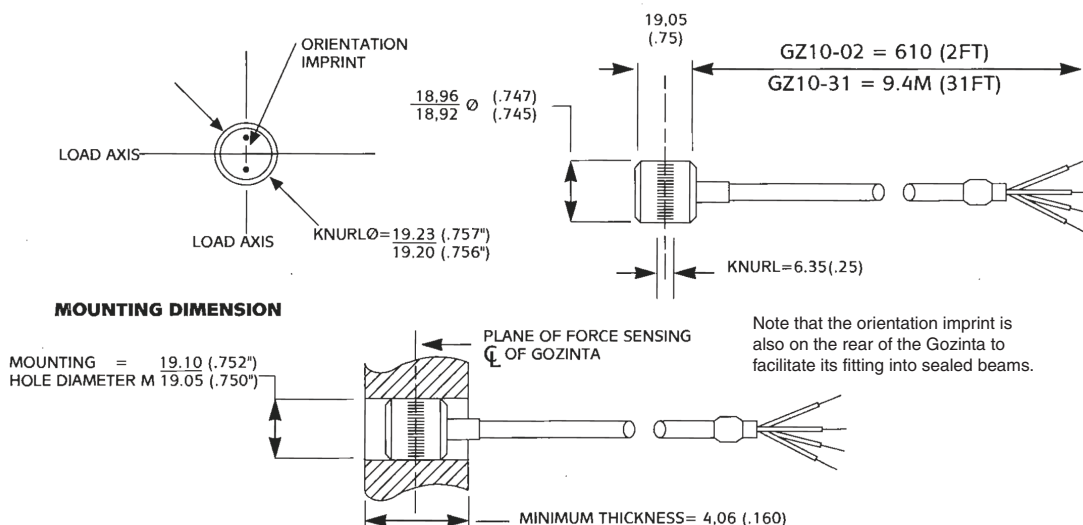

**SPECIFICATIONS**

PARAMETER	VALUE	UNIT
Excitation voltage	up to 15	Vac/Vdc
Zero balance	0.00±0.05 (Prior to installation)	mV/V
Bridge configuration	Full/Double bridge	
Input resistance	700±20	Ω
Output resistance	700±20	Ω
Insulation resistance	≥5000	MΩ
Nonlinearity	±1.0	% FS <sup>1</sup>
Hysteresis	±0.05	% FS <sup>1</sup>
Non-repeatability	±0.1	% FS <sup>1</sup>
Temperature coefficient: Output	0.036	% of reading/°C
Zero	0.35 (-10 to +45°C)	% FS/°C
Temperature range: Storage	-50 to +90	°C
Temperature range: Operating	-40 to +80	°C
Maximum safe output <sup>2</sup>		
Tension	2.5	mV/V
Compression	2.5	mV/V
Shear	4.0	mV/V

1 Specifications for the Gozinta® GZ-10 installed into a mild steel test block (90 x 38 x 305) and subjected to a tensile force of 24000N. Nominal output is 1mV/V. Other specifications are given for uninstalled GZ-10.

2 The maximum safe output for the Gozinta® based on 10<sup>4</sup> full negative to full positive operating cycles (zero to minus to plus to zero).

**Caution:** The endurance limits of the beam must be determined separately.

**Wiring Schematic Diagram**

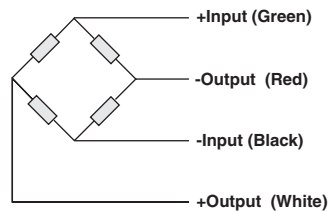

## Disclaimer

All product specifications and data are subject to change without notice.

Vishay Precision Group, Inc., its affiliates, agents, and employees, and all persons acting on its or their behalf (collectively, "Vishay Precision Group"), disclaim any and all liability for any errors, inaccuracies or incompleteness contained herein or in any other disclosure relating to any product.

Vishay Precision Group disclaims any and all liability arising out of the use or application of any product described herein or of any information provided herein to the maximum extent permitted by law. The product specifications do not expand or otherwise modify Vishay Precision Group's terms and conditions of purchase, including but not limited to the warranty expressed therein, which apply to these products.

No license, express or implied, by estoppel or otherwise, to any intellectual property rights is granted by this document or by any conduct of Vishay Precision Group.

The products shown herein are not designed for use in medical, life-saving, or life-sustaining applications unless otherwise expressly indicated. Customers using or selling Vishay Precision Group products not expressly indicated for use in such applications do so entirely at their own risk and agree to fully indemnify Vishay Precision Group for any damages arising or resulting from such use or sale. Please contact authorized Vishay Precision Group personnel to obtain written terms and conditions regarding products designed for such applications.

Product names and markings noted herein may be trademarks of their respective owners.